

# PLANT PULSE -

## *An IOT device for smart farming*

Richa Arora

Third Year BTech-Computer Science  
Engineering  
Ahmednagar  
Maharashtra  
+918275543900  
[richamarora2002.rich@gmail.com](mailto:richamarora2002.rich@gmail.com)

Pradyun Anthati

Third Year BTech-Computer Science  
Engineering  
Mumbai  
Maharashtra  
+919867695136  
[pradyun.gem@gmail.com](mailto:pradyun.gem@gmail.com)

Rahesha Yasin Mulla

Associate Professor  
MIT ADT SOC  
Pune  
Maharashtra  
+919823071906  
[rahesha.mulla@mituniversity.edu.in](mailto:rahesha.mulla@mituniversity.edu.in)

### ABSTRACT

Plants are an essential source of life for humans, providing us with the necessary oxygen, food, and other vital resources. However, we often struggle to provide plants with the essential resources they need to thrive, such as clean water, non-polluted oxygen, and adequate sunlight. This can result in plants withering away and dying, which can have significant environmental and economic impacts.

When you are on a long trip you are not able to water plants and hence the plants dry, but we have a solution for this problem. 'PLANT PULSE'. This is an Energy Efficient Gardening method which will water your plants at the date, time and days you set just by making minor changes in the python code. It enables Real time monitoring, and you can even control this device by using the 'Pi Relay' application.

### Keywords

Energy Efficient Gardening; Precision Agriculture; Weather Conditions; Internet of Things; Autonomous Systems; Real Time Monitoring.

### 1. INTRODUCTION

**Introduction:** Plants are essential to our existence as they provide us with food, oxygen, and other vital resources. However, in our busy lives, we often forget to take care of our plants, leading to their untimely death. To address this issue, we have developed a cutting-edge solution called 'Plant Pulse.' This is an automated watering system that uses Internet of Things (IoT) and can be controlled by a simple Python code. The system ensures that your plants receive the right amount of water at the right time, even when you are away, through Precision Agriculture.

**Importance of IoT for the Project:** IoT is crucial for the Plant Pulse system as it enables remote monitoring and control of the system. With the help of IoT, the system can connect to the cloud, and the user can monitor the system's performance remotely using a mobile application. IoT technology also enables real-time monitoring of soil moisture levels, which helps in conserving water by triggering the watering system only when needed.

**Uses and Importance of the Project:** Plant Pulse is an energy-efficient system that offers a revolutionary method of watering plants, promoting sustainable plant growth. The system allows plants to flourish even when the owner is away for long periods,

making it ideal for people with busy schedules. The system can also be customized by making minor modifications to the Python code, allowing for the specific watering schedule tailored to the needs of the plants.

The project's importance lies in its ability to conserve water by preventing wastage while providing essential care to plants, reducing the environmental impact of watering plants. Moreover, this project can potentially revolutionize Precision Agriculture by providing farmers with an autonomous system that uses IoT to monitor and control water usage for optimal plant growth, reducing costs associated with manual watering.

In conclusion, Plant Pulse is a sustainable and innovative solution to plant care, enabling people to take care of their plants effortlessly while promoting sustainable plant growth. By harnessing the power of IoT and cutting-edge technology, Plant Pulse has the potential to transform Precision Agriculture and plant care in various fields, from homes to industrial farming.

### 2. LITERATURE SURVEY:

"Design and Implementation of an IoT-Based Smart Irrigation System for Precision Agriculture." by D. D. Dede, O. A. Adigun, et al. (2020)

This paper proposes an IoT-based smart irrigation system that uses sensors to measure soil moisture, temperature, and humidity levels. The system is designed to conserve water and promote sustainable agriculture practices.

"Smart Irrigation System Based on IoT for Precision Agriculture." by S. M. Shahnawazuddin, M. K. Hassan, et al. (2019)

This paper presents a smart irrigation system based on IoT technology that uses sensors to monitor soil moisture, temperature, and humidity levels. The system is designed to optimize water usage and reduce waste while promoting sustainable agriculture practices.

"A Low-Cost IoT-Based Automated Irrigation System for Precision Agriculture." by A. K. Halder, M. M. Islam, et al. (2020)

This paper proposes a low-cost IoT-based automated irrigation system that uses sensors to measure soil moisture and humidity levels. The system is designed to optimize water usage and reduce manual labour in precision agriculture.

"Smart Irrigation System for Precision Agriculture Using IoT." by S. S. Kumar, S. K. Kumari, et al. (2018)

This paper presents a smart irrigation system for precision agriculture that uses IoT technology and sensors to measure soil moisture, temperature, and humidity levels.

### 3. PROJECT MOTIVATION:

This project has given us the opportunity to explore our creativity and apply our knowledge to address a critical need in our society. As we look towards the future, our dream is to continue building upon the success of this project and make it accessible to every individual in India who can benefit from it.

Our goal is to not only achieve success as entrepreneurs, but also to make a positive impact on the lives of people by providing them with an efficient and effective solution for plant irrigation. With the rapid advancements in technology, we believe that our idea has the potential to revolutionize the way we approach sustainable agriculture and contribute to the progress of humankind as a whole. With the advancement of the technology the idea behind this project can boost up the progress of entire mankind and hence make it easier and worth living.

#### 3.1 PROPOSED SYSTEM:

The implementation phase of the project involves the careful execution of the design developed in the previous phase. The project aims to create an automated agricultural system that will reduce costs and revolutionize the irrigation process. The system will use Internet of Things (IoT) technology and real-time monitoring to conserve water while also providing convenient plant care. The target industry is the food and beverage industry, which is seeking cost-effective ways to improve agricultural productivity. Ultimately, the project aims to benefit the farmers who are the backbone of the agricultural economy.

Flowchart:

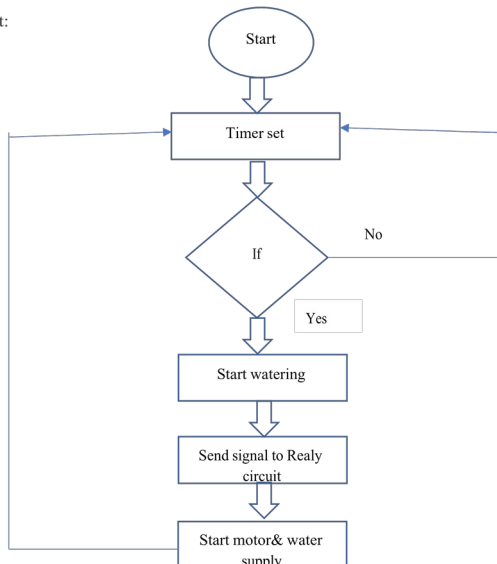

#### 3.2 METHODOLOGY:

**System Design:** The first step in developing the smart watering system is to design the system. This includes selecting the

components such as Raspberry Pi, relay, motors and other necessary hardware.

**Software Development:** The software development phase involves writing Python code to control the system. This includes creating the logic for motor and relay and activate the motor to water the plants.

**Connectivity:** The system will use Internet of Things (IoT) technology to connect the Raspberry Pi to the cloud. This will allow for remote monitoring and control of the system from a mobile application.

**Motor Integration:** The motor will be integrated into the system and connected to the Raspberry Pi. The motor will be activated according to the schedule.

**Mobile Application Development:** A mobile application will be developed to allow for remote monitoring and control of the system. The application will display real-time data from the sensors and allow the user to adjust watering schedules as needed.

**Testing and Validation:** The system will undergo rigorous testing and validation to ensure that it meets the required performance standards.

**Deployment:** Once the system has been tested and validated, it will be deployed in the field. The system will be installed in the desired location and connected to the cloud for remote monitoring and control.

**Maintenance:** The system will require regular maintenance to ensure that it continues to function properly. This includes monitoring the components and making necessary adjustments to the watering schedule.

By following this methodology, the smart watering system will be created, and it will help in conserving water by using real-time monitoring of soil moisture levels to trigger the watering system. Additionally, the system will help in reducing costs associated with manual watering and improve plant care.

#### TECHNICAL FEASIBILITY OF OUR PROJECT:

1. effortless gardening
2. cost effective
3. saves time
4. unattended watering
5. water is saved to great extent
6. accuracy in watering of different plants

#### 3.3 ECONOMIC SUSTAINIBILITY:

Our project, the 'PLANT PULSE', is a financially viable solution due to its underlying platform - the Raspberry Pi. The Raspberry Pi is easily available at a relatively affordable price, making our solution accessible to a wider range of customers.

Moreover, our project is 100% achievable due to its straightforward implementation process. All that is required is to add a code to the Raspberry Pi and modify the device to make it compatible with our system. This makes our solution easy to integrate into everyday life, providing a simple and effective method for automating plant irrigation.

Given the significant challenges associated with irrigation in many homes and farms, our product has the potential to provide immense benefits to the wider community. Our solution offers an efficient and sustainable alternative to traditional watering

methods, minimizing water usage while promoting plant health and growth.

With our innovative technology, we aim to revolutionize the way we approach gardening and agriculture, making it more accessible, efficient, and sustainable. By providing an affordable and practical solution to the challenges associated with plant irrigation, we hope to empower individuals and communities to lead healthier and more sustainable lives.

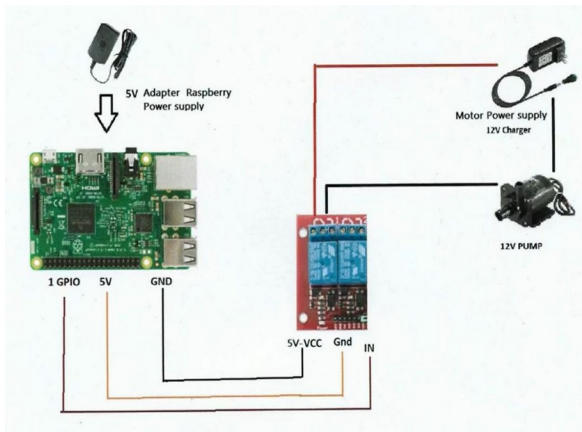

Figure 1- Circuit Diagram-Plant Pulse

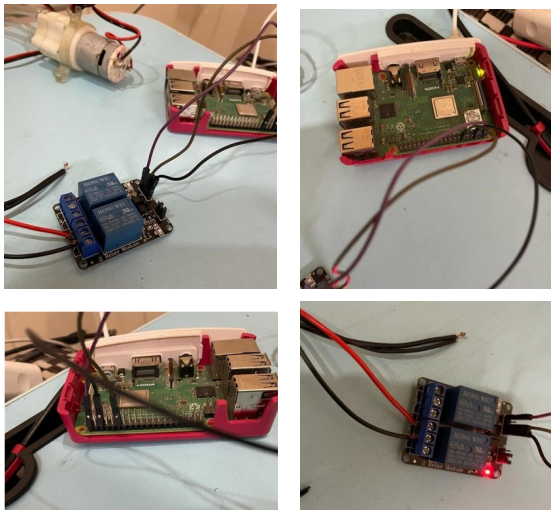

Figure 2 – Working model of our project

### 3.4 REQUIREMENT SPECIFICATION:

#### Software requirements:

- Pi Relay application - This is an application that can be installed on the Raspberry Pi to control the submersible motor that is used for watering the plants. It allows users to remotely control the watering schedule for their plants using a mobile device or computer.
- IFTTT - This stands for "If This Then That", and is a web-based service that allows users to create applets

that trigger an action based on a specific event. In this case, it can be used to trigger the watering of plants based on specific criteria, such as the weather forecast or time of day.

- Python 3.9 - This is a high-level programming language that is used to write the code that controls the Raspberry Pi and the submersible motor. It is a widely used language in the field of automation and is particularly well-suited for IoT (Internet of Things) applications.

#### Hardware requirements:

- Raspberry Pi 3B+ - This is a single-board computer that serves as the central processing unit for the 'PLANT PULSE' system. It is a low-cost, energy-efficient device that can run a range of operating systems and is widely used in DIY electronics projects.
- 12-volt submersible motor - This is a small motor that is used to pump water from a reservoir to the plant pot. It is submersible, which means it can be placed directly into the water source and is powered by a 12-volt power supply.
- 5-volt motor - This is a small motor that is used to control the opening and closing of the water valve. It is powered by a 5-volt power supply and is connected to the Raspberry Pi using connecting wires.
- Connecting wires - These are wires that are used to connect the various components of the 'PLANT PULSE' system, including the Raspberry Pi, motors, and sensors. They come in a range of sizes and can be used to make a variety of different connections.

### 4. FUTURE SCOPE

Our team is dedicated to further developing our project with a focus on optimizing its functionality through the integration of advanced sensors, specifically humidity sensors, soil sensors, and temperature sensors. We recognize the potential for this technology to positively impact the lives of citizens across India, and our goal is to make this project accessible and beneficial to all who require it.

By leveraging the valuable data provided by these sensors, we can gain insights into the critical environmental factors that impact plant growth and yield. With this information, we can improve the efficiency of our project by developing precise algorithms to regulate watering schedules, nutrient delivery, and temperature control. This will enable us to maximize crop production while minimizing resource waste.

Our team's ambition is to create a scalable and reliable system that can be replicated in various locations throughout India, providing a sustainable solution to food insecurity. As entrepreneurs, we recognize the importance of creating a valuable product that benefits society while also achieving our personal goals of success and fulfillment.

### 5. CONCLUSION:

This project presents the architecture and implementation of an innovative Plant Pulse system. Our solution addresses the critical challenge of ensuring regular watering intervals for plants, regardless of external weather conditions.

Our solution not only ensures the healthy growth and yield of plants but also minimizes water usage, thus contributing to

environmental sustainability. Furthermore, our automated gardener can be easily adapted to a wide range of indoor and outdoor planting scenarios, making it a versatile solution for modern-day gardening.

In summary, this project showcases our innovative approach to automated gardening and provides a significant contribution to the field of smart agriculture. Our system's robust performance and scalability make it a valuable solution for various planting scenarios, enabling us to address the pressing challenges of food security and environmental sustainability.

## ACKNOWLEDGMENTS

It is our honor to present the project report on 'Plant Pulse', which has been the culmination of our efforts and dedication to create a technology-driven solution to address the issue of food security in India.

We extend our heartfelt gratitude to our internal guide, Prof. Rahesha Mulla, for her unwavering support, guidance, and valuable insights throughout the project. Her expertise and mentorship have been instrumental in shaping our work and achieving our goals.

We would also like to express our sincere appreciation to Dr. Shradha Phansalkar, Head of Computer Science & Engineering, for her invaluable support and constructive feedback. Her encouragement and suggestions have been crucial in strengthening our project and ensuring its successful completion.

Furthermore, we would like to extend our special thanks to Rajneesh Kaur Sachdeov, Director of School of Computing, for providing us with state-of-the-art laboratory facilities equipped with all the necessary software platforms and continuous internet connectivity. These resources were instrumental in enabling us to conduct our research and implement our ideas effectively.

We are grateful for the opportunity to work on this project and for the assistance provided by our esteemed mentors and institution.

## 6. REFERENCES

[1] Pankaj, Pankaj, et al. "Smart irrigation system using IoT." 2020 3rd International Conference on Computing Methodologies and Communication (ICCMC). IEEE, 2020.

[2] Bhattacharyya, Sayan, et al. "Smart Irrigation System with IoT." 2021 4th International Conference on Computing, Communication and Security (ICCCS). IEEE, 2021.

[3] Khan, Reaz Uddin, and Abdul Hamid. "Smart agriculture using IoT: a review." *Journal of Sensor and Actuator Networks* 8.2 (2019): 28.

[4] Dubey, Rishi, et al. "IOT based smart irrigation system using soil moisture sensor." 2020 6th International Conference on Advanced Computing and Communication Systems (ICACCS). IEEE, 2020.

[5] Jha, Shubham, and Khushboo Sharma. "Smart farming using IoT: A review." 2021 7th International Conference on Advanced Computing and Communication Systems (ICACCS). IEEE, 2021.

[6] Baluprithviraj, K. N., et al. "Design and Development of Automatic Gardening System using IoT." 2021. International Conference on Recent Trends on Electronics, Information, Communication & Technology (RTEICT). IEEE, 2021.

[7] Muhtasim, Md Adib, Syeda Ramisa Fariha, and Ashique Mohaimin Ornan. "Smart garden automated and real time plant watering and lighting system with security features." 2018 International Conference on Computing, Power and Communication Technologies (GUCON). IEEE, 2018.

[8] Baluprithviraj, K. N., et al. "Design and Development of Automatic Gardening System using IoT." 2021 International Conference on Recent Trends on Electronics, Information, Communication & Technology (RTEICT). IEEE, 2021.

[9] Sambath, M., et al. "Iot based garden monitoring system." *Journal of Physics: Conference Series*. Vol. 1362. No. IOP Publishing, 2019. Gartner cloud computing definition, <http://www.gartner.com/itglossary/cloud-computing/> Naïve Bayes Classifier, Wikipedia, [en.wikipedia.org/wiki/Naïve\\_Bayes\\_Classifier](https://en.wikipedia.org/wiki/Naïve_Bayes_Classifier)

[10] Rahman, Md Shahidur, et al. "A comprehensive review on IoT based smart greenhouse and its applications." *Computers and Electronics in Agriculture* 174 (2020): 105507.

[11] Mali, Dhanshri and RTP, Ramesh, O.W. Tembhurne (March 21, 2019)., "Real-Time Smart Surveillance System Using Raspberry Pi" In Proceedings of International Conference on Sustainable Computing in Science, Technology and Management (SUSCOM-2019), February 26 - 28, 2019, Amity University Rajasthan, Jaipur, India.