

AUTO CLEANING CENTRIFUGE SYSTEM

Shubham Pol
Dept. Of Mechanical Engineering
MIT ADT University
Pune, India
shubhampol2000@gmail.com

Pankaj Shelar
Dept. Of Mechanical Engineering
MIT ADT University
Pune, India
prshelar87@gmail.com

Prof. Ashwinkumar Mahindrakar
Dept. Of Mechanical Engineering
MIT ADT University
Pune, India
ashwinkumar.mahindrakar@mituniversity.edu.in

Saurabh Gaikwad
Dept. Of Mechanical Engineering
MIT ADT University
Pune, India
saurabhgaikwad01442@gmail.com

Shreyash Dayma
Dept. Of Mechanical Engineering
MIT ADT University
Pune, India
shreyashdayma@gmail.com

Prof. Vijaykumar Shep
Dept. Of Mechanical Engineering
MIT ADT University
Pune, India
vijaykumar.shep@mituniversity.edu.in

Abstract

Every day is a rise in factories and industries producing automobiles, metals like steel, iron, etc. All such industries are in constant requirement of oil for lubrication or other purposes. But during such process, the oil gets unprocessed making it difficult to use repeatedly. Among the available systems, the Centrifugal Filtration system was chosen to meet the expectations. Due to the automation in the proposed system the accuracy of the system is bound to increase as well as decreasing the manual work. In the current era of automation, it is expected that systems work for large amount of time, so it being an automated system, the sludge will be disposed at regular intervals thus increasing its operating time during the iterations, this disposal of sludge is carried out by system's Improved Scraping Mechanism.

Keywords— *Centrifuge, Automation, Filtration, Scraping Mechanism, Oil Sludge*

I. INTRODUCTION

Centrifuges are used in industry for a number of purposes including the separation of materials based on density. This separation normally entails removing insoluble particles from supernatant liquids, but it can also entail extracting dissolved compounds from one immiscible liquid into another of a different density and centrifugally separating the combined liquids. The liquids are blended, the solute is transferred, and the immiscible phases are separated successively in the same machine at high speed. Centrifuges are commonly employed in numerous manufacturing industries to separate solids from liquids by using centrifugal acceleration of particles directed outward from the rotation axis. This force causes the particles to travel to the centrifuge's perimeter, where they are confined or contained by the rotating body's wall. Alternatively, a density difference between two immiscible liquids can be used to speed up liquid separation (for example, fat separation in dairies for cream or butter production) [8].

There are various types of centrifuges available today some of them are mentioned as follows:

Decanter centrifuge: - The primary use of decanter centrifuges is to continuously separate enormous volumes of particulates from liquids. They're also utilized in industry to

clean and dry different substances like polystyrene beads, clarify liquids, and concentrate solids.

Disc stack centrifuge: - A centrifugal separator known as a disc stack centrifuge is a type of centrifugal separator. In the bowl of a centrifugal separator, a set of conical plates (disc stack) is inserted. More settling space is introduced with the addition of the 'disc stack.' Thus, increased surface area accelerates the separation process.

Solid bowl centrifuge: - The spinning assembly of a solid bowl centrifuge (SBC) consists of a horizontal centrifuge rotor with a scroll conveyor inside it. The assembly spins at a rapid rate around its own axis, providing a strong centrifugal force that allows solids to separate from liquid.

Tubular centrifuge: - Tubular centrifuges are made out of a bowl, a slow acceleration motor, and a starting. The bowl revolves at 15000 rpm, producing a centrifugal force 16000 times that of gravity. The liquid combination to be separated enters the Centrifuge's nozzle, which is located at the bottom of the base [8].

The rising industrial usage of centrifuges has resulted in a variety of customized centrifuges built and modified to specific needs during the last 10-15 years. Sedimentation centrifuges and filter centrifuges are the two types of centrifuges available. Solids are delivered to the revolving machine bowl's perimeter wall and gathered against this surface in sedimentation centrifuges; liquid is separated from the solids by the tight packing of the individual particles. Solids are brought to the surface of a filter element and trapped on this filter, while liquid drains through the particles and escapes through the filter surface in filter centrifuges. The G-force generated due to the rotational motion acts differently on the pumped liquid and the suspended solids inside it because of the density difference. Hence, the solids get concentrated on the centrifuge inner walls of the pot while clean liquid flows out [8].

II. RESEARCH GAP AND EXISTING TECHNIQUES

There is less research done in this field of centrifuge for testing. The manual method is used for cleaning the sludge

from the centrifuge in some of the industries, it also requires a lot of time and human labor, Hence the productivity becomes low and the cost increases.

Therefore, the Automated centrifuge comes in picture, auto cleaning centrifuge system using the scraping mechanism with the help of the actuator and the pneumatic cylinder is easier to integrate, time saving, economical, and does not need human labor.

III. PROPOSED SYSTEM



Figure 1: - 3D model of Auto cleaning centrifuge system

Proposed automated system for cleaning centrifuge consists of the upper plate, housing, centrifugal pot, shaft, scraper, actuator, pneumatic cylinder and coupling done inside the pot.

The linear actuator is a device that travels in a linear motion between two places. Mechanical, electro-mechanical, direct electric (linear motors), hydraulic, and pneumatic linear actuators are among the various technologies.

Scraper - It entails the use of a sharp instrument that is mostly employed in the cleaning procedure. The scraper, which is generally a tool with a pointed side, is scraped on the wall to be cleaned in this method. The scraper in the gadget will assist in cleaning the inside walls of the pot, resulting in sludge scraping.

IV. COMPONENTS AND WORKING OF THE SYSTEM

1. Actuator:

An actuator is a component of machine which is responsible for moving or controlling a mechanism or system. It is a device that uses a form of power to convert control signal into mechanical motion. An actuator requires a control signal and a source of energy. In this device, the use of actuator is to drive the arm to which the scraping mechanism is attached. The actuator used in this device is a Linear Actuator.

Linear actuator are the ones that converts rotational motion into linear motion. The movement of the actuator can be powered by the use of Hydraulics or Pneumatics.



Figure 2: -Linear actuator [10]

The specifications of the actuator used is as follows:

Table 1: -

Actuator Type	Linear Actuator
Voltage	24 V DC
Valve Motion	Linear Motion Valve
Stroke Length	100mm
Rated Load	500 N
Speed at rated load	20mm/sec

2. Scraper:

It involves a sharp tool which is mainly used in cleaning process. In this, the scraper which is usually a tool with a pointed side is being scraped on the wall which is to be cleaned. In the device, the scraper will help in cleaning the inner walls of the pot which will result in scraping of sludge. The scrapping tool is attached to an arm. The arm is driven by an actuator which will bring the arm down when maximum sludge level is reached. In the previous solutions, the removal/falling of the sludge was fully/partially dependent on gravitational force. But using the scraping mechanism is an advantage for easy removal of the sludge.

3. Pneumatic Cylinder:

Pneumatics can be described as a technology of pressurized air using piped or compressed air to transmit force and energy. The role of the pneumatic cylinder is to open the cork which is at the lower end of the pot. Using the pneumatic cylinder, the cork or lower plate will be opened for the sludge to pass out. The pneumatic cylinder is mounted on the lower plate from down side. The mountings will be done by front flange mounting method.



Figure 3: - Pneumatic cylinder [9]

Specifications: -

Temperature: - 60 degree C
 Stroke length – 250 mm

4. Coupling:

A coupling is a mechanical element/part that connects two shafts together to transmit power from the drive side to the driven side. The need of coupling in the device is to rotate the pot with the help of the motor which is mounted on the upper end. The coupling used in the device is a standard sized flange coupling with Internal Diameter of 30mm. The coupling attached will be bolted by using M10 type of bolts.



Figure 4: - Coupling

5. Housing:

It is the outer body on which the whole device is mounted. There are provisions made for the inlet and outlet as well as shaft and actuator. It acts as a cover for the device as well as for maintaining the stability during the rotation of pot. The material used for housing will be a 3mm Mild Steel plate. The purpose of selecting Mild Steel is because of its properties. It has low self-weight and high strength to weight ratio. It has high ductility and durability. Also, it is a low cost, moldable and easy to transport material. This solution is final solution and may be considered for manufacturing.

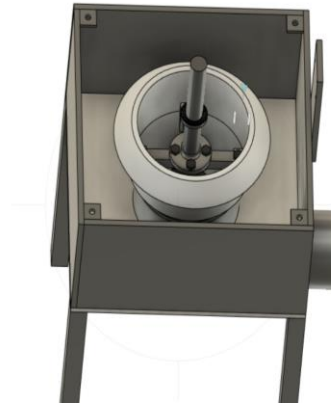

Figure 5: - Housing and coupling done inside the centrifugal pot

Working: In this solution, scraping mechanism is included for easy removal of sludge. In this solution, when the maximum level of sludge is reached, the oil flow from inlet will be ceased temporarily. Then the actuator will move down the arm to which the scraper is attached. The pot will be allowed to rotate at a certain RPM. This will ensure that all the sludge stuck on the inner walls of the pot is removed properly. Simultaneously, the lower cork will open with the help of pneumatic cylinder. As the lower end is opened, the sludge will fall with the help of gravitational force. As the sludge is excreted completely, the lower cork will again close the opening of the pot and the filtration process will be continued again.



Figure 6: - Design of the centrifuge

In this solution, only the pot will be in rotation motion. All the remaining parts will be stable. The rotating motion of the pot will be achieved by a shaft attached to the inner walls of the pot. Thus, with all these steps being processed, the required output may be achieved.

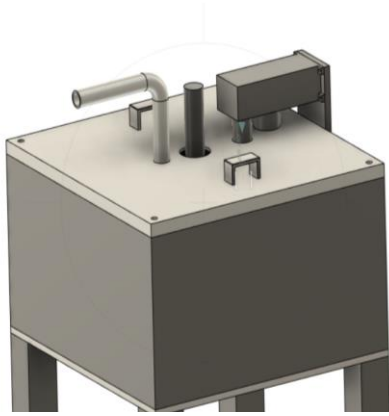

Figure 7: - Inlet of oil and actuator

V. CONCLUSION

The working of the system is mainly based on the automated cleaning centrifuge system where the system decreases manual work and human labor thus increasing productivity and operating time by the improved scraping mechanism and pneumatic discharge system.

VI. Acknowledgement

We express our profound thanks to Guide **Prof. Ashwinkumar Mahindrakar and Prof. Vijaykumar Shep** Mechanical Engineering, MIT School of Engineering, MIT-ADT University, Pune for their expert guidance, encouragement and inspiration during this project work.

REFERENCES

- [1] A. Cambiella, J. M. Benito, C. Pazoz, J. Coca; 'Centrifugal Separation Efficiency in the Treatment of Waste Emulsified Oils'; Volume 84; Issue 1; 2006; pp 69-76.
- [2] R. K. Pandey, V. P. Agrawal; 'Design and Development of Centrifugal Oil Filter for Fine Filtration'; Industrial Tribology, ITMMEC, IIT D; 2004.
- [3] Murray Lyons, Scott Simmons, Maxwell Fisher, J. S. Williams, W. D. Lubitz; 'Experimental Investigation of Archimedes Screw Pump'; Volume 146; Issue 8; August 2020.
- [4] Ying-Chien, Jia-Hao, Jeng-Nan, Wen-Yuh; 'Development and Implementation of Automatic Scraping Mechanism'; Advanced Science Letters; Volume 8; 2012; pp 211-215.
- [5] O. Ustun, R. N. Tuncay; 'Design, Analysis and Control of a Novel Linear Actuator'; Volume 42; Issue 4; August 2006; pp 1007-1013
- [6] Diego Ramirez, Chris D. Collins; 'Maximisation of oil recovery from an oil-water separator sludge: Influence of type, concentration, and application ratio of surfactants', Waste Management 82, 2018, 100-110
- [7] Jiu Xu, Pega Hrnjak; 'Impinging of Oil Separator for Compressors', International Journal Refrigeration 119, 2020, 110-118
- [8] T. Beveridge; 'Large Scale Centrifugation', 2000
- [9] Janatics product catalogue, 2021
- [10] Progressive automations catalogue, 2014